

# T-203 Tapping Machine

Sizes: 4- to 12-inch

Model T-203c



Bulletin No: 1000.003.03

Date: 04.2024

Supersedes: 1000.003.02 (10.2019)



## Description

Tapping machines are used to make connections to pipelines, tanks and plant piping and are used to make hot taps in preparation for plugging machine applications.

The T-203 Tapping Machine is used for making 4" to 12" (DN 100 to DN 300) taps without shutdown in pipelines, primarily for the installation of TDW SHORTSTOPP® Plugging Machines.

## Features

The T-203 Tapping Machine has an adjustable automatic feed rate of 0 to 1/8" per revolution for any cutting condition.

The T-203 Tapping Machine operates at a maximum of 740 psi (50 bar) @ 100°F (38°C). Its operating temperature is -20° F (-29° C) to 180°F (82°C) @ 675 psi (46 bar). It weighs 241 pounds (109 kg.), including the air motor drive, which is standard equipment. Lightweight with a low center of gravity, it is designed to be easy to handle and to operate.

The T-203 Tapping Machine also features a four-bolt attachment to the valve adapter. This provides a simple, rigid makeup with proper cutter alignment.

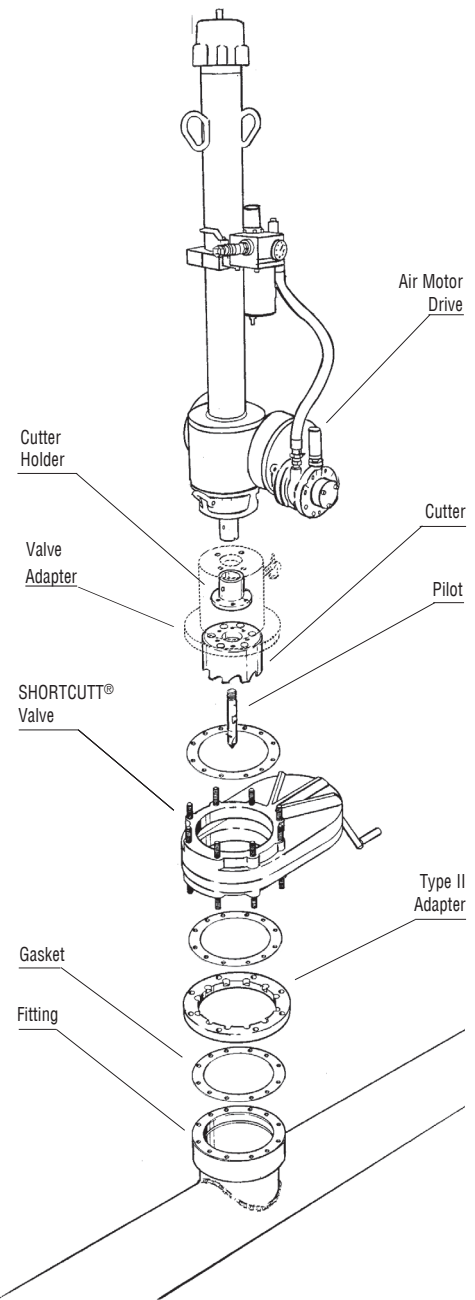



**Dimensions and Part**

# T-203 Tapping Machine

Basic Machine	Wt./Lb.	Wt./Kg.	Part Number
with air drive assembly and carrying case	366	166	12396417
with hydraulic drive assembly and carrying case	400	181	05-2174-0000

## Specifications

Boring Bar Travel		Overall Length		Rate of Travel per revolution		Feed Mechanism
Inch	mm	Inch	mm	Inch	mm	
36	914	58	1473	0-1/8	0-3	adjustable, automatic

## Operating Specifications

Maximum Operating Pressure	740 psi (50 bar) @100°F (38°C)
Maximum Operating Temperature	180°F (82°C) @ 675 psi (46 bar)

## Adapters

		Max. Working Pressure				Max. Working Pressure			
		Class 150				Class 300			
Inch	mm	psi	Wt./Lb.	Wt./Kg.	Part Number	psi	Wt./Lb.	Wt./Kg.	Part Number
4	100	285	29	13	06-1542-0000	740	38	17.2	06-7370-0000
6	150	285	39	18	06-1543-0000	740	65	29.5	06-7371-0000
8	200	285	60	27	06-1544-0000	740	95	43.1	06-7372-0000
10	250	285	87	39	06-1545-0000	740	140	63.5	06-7373-0000
12	300	285	130	59	06-1546-0000	740	205	93	06-7374-0000

## Cutters & Pilot Drills

				SHORTSTOPP® Cutters			SHORTSTOPP® Pilot Drills			
Nominal Size		Actual Size		Weight			Weight			
Inches	mm	Inches	mm	Lb.	Kg.	Part Number	Lb.	Kg.	Part Number	Spare U-Rods
4	100	3-7/8	98	3	1	05-0255-0004	1	.5	05-0247-0003	00-1424-0005
6	150	5-7/8	149	8-3/4	4	05-0330-0006	2	1	05-0293-0002	00-1424-0003
8	200	7-3/4	197	20	9	05-0330-0008	2	1	05-0293-0003	00-1424-0003
10	250	9-3/4	248	23	10	05-0330-0010	2	1	05-0293-0004	00-1424-0003
12	300	11-3/4	299	40	18	05-0330-0012	2.5	1.1	05-0293-0005	00-1424-0003

## Cutter Holders, Bleeder Valve & Nipple

	Inch	mm	Wt./Lb.	Wt./Kg.	Part Number
Cutter Drive Key	4	80	0.5	0.25	05-0227-0000
Cutter Holder	6-12	150-300	9	4	05-0326-0000
Bleeder Valve	--	--	--	--	00-0774-0001
Nipple	--	--	--	--	00-0220-0001
Spare U-Rods	4	--	--	--	00-1424-0005
Spare U-Rods	6-12	--	--	--	00-1424-0003